

# WHS-M-S3-XX MANIFOLD

## Overview

The Warmup S3 Manifold range provides flexible zoning and water regulation for 2 to 12 underfloor heating circuits. Supplied complete with Taconova TopMeters, Fill/Drain Valves, Air Vents and a Thermomanometer, it is equipped with all the features needed to commission an underfloor heating system quickly and confidently.

Available separately, the Warmup Mixing Unit provides water temperature regulation between 20°C and 60°C, for tailored system performance.

Mixing units are required for all installations where the temperature of the water provided by the heat source either does or could exceed the design water temperature of the floor heating system. This includes all heat sources which intermittently 'over heat' due to sterilisation cycles or uncontrolled heating.

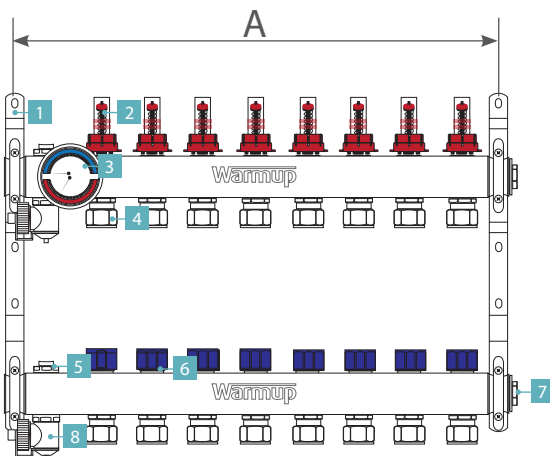

### MANIFOLD

1 Mounting Bracket	5 Manual Air Vent
2 Flow Gauge	6 Commissioning Cap
3 Thermomanometer	7 End Cap
4 Eurocone Connector	8 Fill/Drain Valve

Manifold Type	Height	Depth	Width/No. of Ports										
			2	3	4	5	6	7	8	9	10	11	12
Excluding Mixing Unit	340	95	190	240	290	340	390	440	490	540	590	640	690
Including Mixing Unit	450	128	490	540	590	640	690	740	790	840	890	940	990
Bracket Spacing (A)			165	215	265	315	365	415	465	515	565	615	665



Hydronic  
Heating System

**Warmup**

The world's best-selling floor heating brand™

0345 345 2288

uk@warmup.com  
www.warmup.co.uk

# Features

## Manifold

- Thermomanometer on the flow arm allows for easy pressure testing, system commissioning and 'at a glance' operational checks thereafter
- Taconova TopMeter flow gauges provide quick, accurate and reliable water regulation
- 5th Generation Möhlenhoff actuators combine their renowned reliability with just 1W power usage
- 10 Year Warranty



# Technical Specifications

MANIFOLD - TECHNICAL SPECIFICATIONS	
MATERIAL	304 Stainless Steel
PORTS AVAILABLE	2 - 12
TEMPERATURE RANGE	-5°C to +60°C
MAX OPERATING PRESSURE	6 Bar
MAX TEST PRESSURE	10 Bar
ADJUSTMENT RANGE	0 - 5 l/min
MEASURING ACCURACY	±10% (of highest nominal value)
MANIFOLD ARM DIMENSIONS	40 mm X 40 mm
PIPE FITTING CENTRES	50 mm
PIPE FITTING DIAMETERS	G-3/4"